

PROJ. 
 DOS/005 REFERS

DO NOT SCALE

CAD ORIGINAL DO NOT ALTER BY HAND

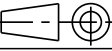
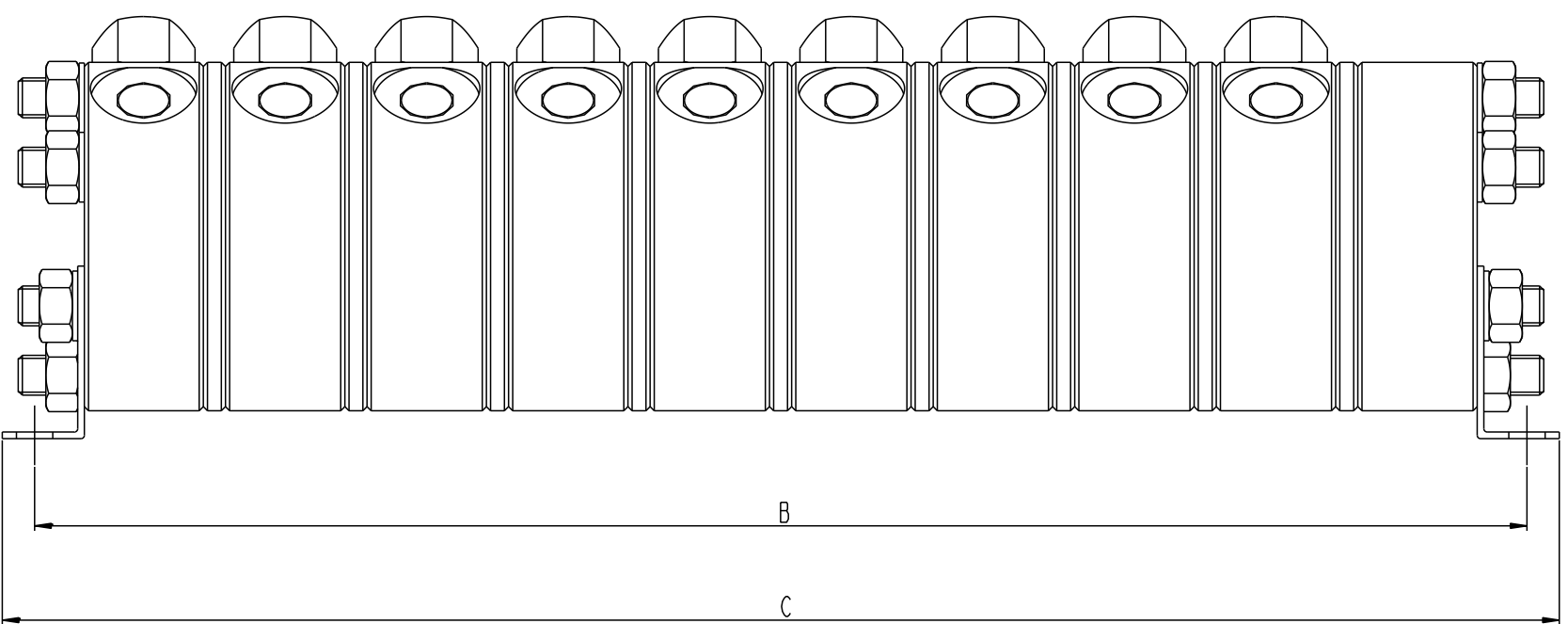
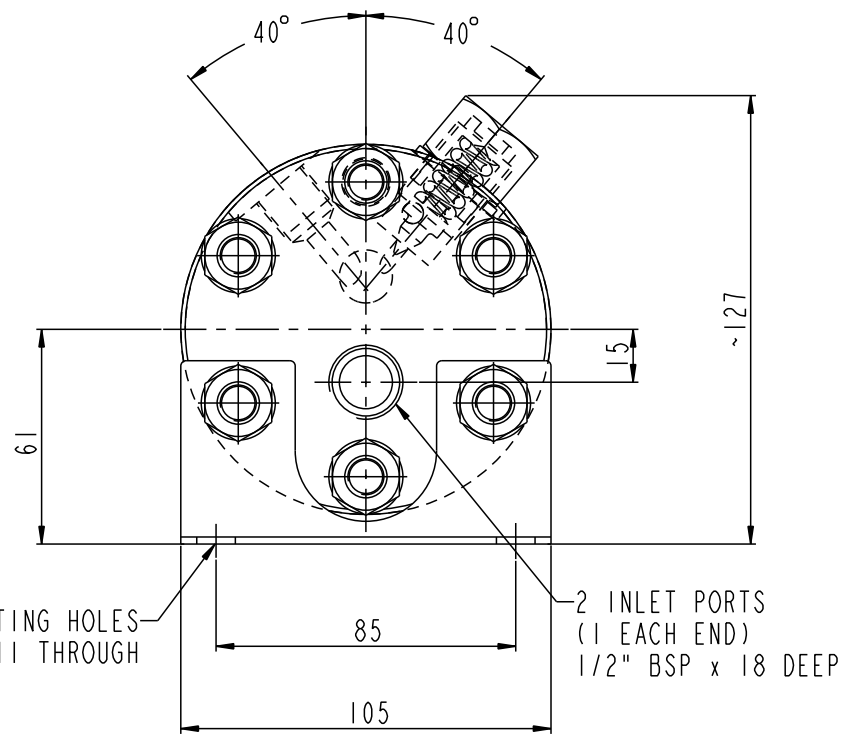

TYPE	DIM 'A'	DIM 'B'	DIM 'C'	FLOW RANGE
FDR 9/2	42.6	448.9	468.9	13-54 L/MIN
FDR 9/4	49.3	508.9	528.9	27-108 L/MIN
FDR 9/6	56	568.8	588.8	40-162 L/MIN
FDR 9/9	66	659.0	679.0	61-244 L/MIN

MOUNTING POSITION (DIM 'B') ± 1.36
 DUE TO COMPONENT TOLERANCES

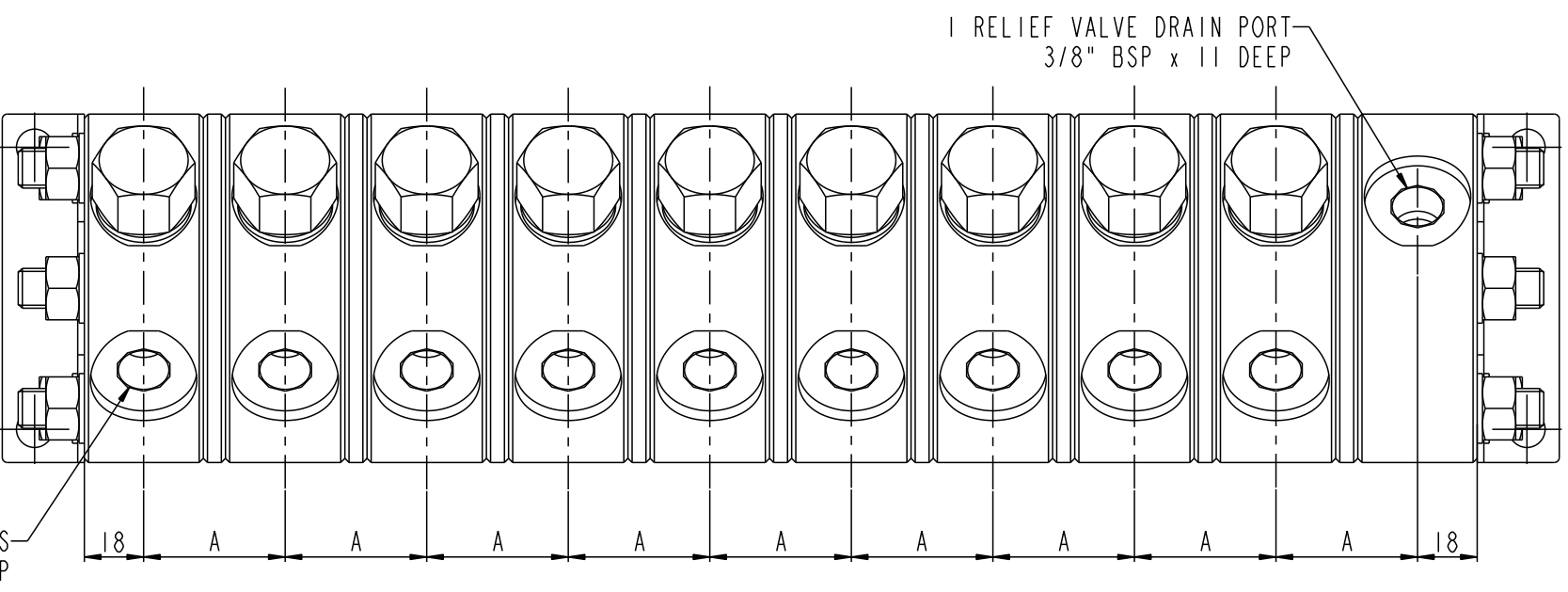

GEOMETRIC TOLERANCE SYMBOLS REF. B.S. 308 : PART 3 : 1990		MATERIAL		IDENTITY ZONE		TEXT	
STRAIGHTNESS	—	PARALLELISM	//	SYMMETRY	≡	DIMENSIONS IN MM & INCHES	SCALE 1:1
FLATNESS	▭	SQUARENESS	⊥	M.M.C.	⊕	SURF. TEXT IN ROUGHNESS NOS.	DR 'N. SGT 16-Mar-06
ROUNDNESS	○	ANGULARITY	∠	MACHINE	✓	TOL. UNLESS STATED	CH'D.
CYLINDRICITY	⊘	RUN OUT	↗	M/C OPTIONAL	✓	DIMENSIONAL ±	TITLE
PROF. OF A LINE	⌒	POSITION	⊕	DO NOT M/C	✓	SIM. TO	PLS
PROF. OF A SURF.	⌒	CONCENTRICITY	◎	TAPER	▽	FLOW DIVIDER ASSEMBLY-9 WAY	

REV.	ZONE	ALTERATION	SIG. & DATE	CAT.	PROF. OF A SURF.	CONCENTRICITY	◎	TAPER	▽	PATT.	CLASS	DRG. NO.	SHEET	REVISION
												1 OF 1		

SLACK & PARR LTD.
 KEGWORTH-DERBY-ENGLAND
 PROJ./TYPE/SERIAL NO.
 TITLE
 FLOW DIVIDER ASSEMBLY-9 WAY
 DRG. NO. HB830327
 SHEET 1 OF 1
 DATE 16-Mar-06
 © SLACK & PARR LTD. 2006 THE DESIGN AND INFORMATION CONTAINED IN THIS DRAWING IS STRICTLY CONFIDENTIAL AND IS THE EXCLUSIVE PROPERTY OF SLACK & PARR LIMITED AND MUST NOT BE USED, COPIED OR REPRODUCED IN PART OR WHOLE WITHOUT WRITTEN PERMISSION FROM SLACK & PARR LIMITED